

10-32 Female to BNC Male Adapter



TECHNICAL DATA SHEET

PE9750

10-32 Female to BNC Male Adapter

Configuration

Connector 1	10-32 Female
Impedance 1	50 Ohms
Connector 2	BNC Male
Impedance 2	50 Ohms
Adapter Design	Standard
Body Style	Straight

Mechanical Specifications

Size

Length, in [mm]	1.106 [28.09]
Width/Dia., in [mm]	0.57 [14.48]

Connector 1

Type	10-32 Female
Inner Conductor Material and Plating	Gold
Body Material and Plating	Brass, Nickel
Dielectric Type	PTFE

Connector 2

Type	BNC Male
Inner Conductor Material and Plating	Gold
Coupling Nut Material and Plating	Brass, Nickel
Body Material and Plating	Brass, Nickel
Dielectric Type	PTFE

Compliance Certifications (visit www.Pasternack.com for current document)

RoHS Compliant	Yes
----------------	-----

Plotted and Other Data

Notes:	Values at 25 °C, sea level
--------	----------------------------

URL: <http://www.pasternack.com/10-32-female-bnc-male-straight-adapter-pe9750-p.aspx>

10-32 Female to BNC Male Adapter from Pasternack Enterprises has same day shipment for domestic and International orders. Our RF, microwave and fiber optic products maintain a 99% availability and are part of the broadest selection in the industry.

The information contained in this document is accurate to the best of our knowledge and representative of the part described herein. It may be necessary to make modifications to the part and/or the documentation of the part, in order to implement improvements. Pasternack reserves the right to make such changes as required. Unless otherwise stated, all specifications are nominal.

PE9750 CAD Drawing
10-32 Female to BNC Male Adapter

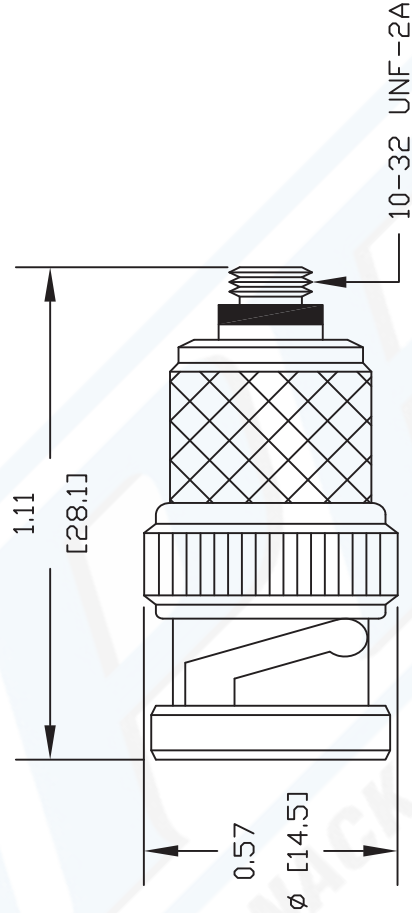

NOTES:
 1. UNLESS OTHERWISE SPECIFIED ALL DIMENSIONS ARE NOMINAL.
 2. ALL SPECIFICATIONS ARE SUBJECT TO CHANGE WITHOUT NOTICE AT ANY TIME.
 3. DIMENSIONS ARE IN INCHES [mm].

DWG TITLE
PE9750

PASTERNAK ENTERPRISES, INC.
 P O BOX 16759, IRVINE, CA 92623
 PHONE (949) 261-1920 FAX (949) 261-7451
 WEB ADDRESS: www.pasternack.com
 E-MAIL ADDRESS: sales@pasternack.com
COAXIAL & FIBER OPTICS



REV. -	FSCM NO. 53919	CAD FILE 071703	SCALE N/A	SIZE A	127
--------	----------------	-----------------	-----------	--------	-----