

**Thank you for choosing a NIVELCO instrument.
We are sure that you will be satisfied throughout its use.**

NIVOPRESS

HYDROSTATIC LEVEL TRANSMITTER

USER'S MANUAL



NIVELCO

1. APPLICATION

The NIVOPRESS N submersible hydrostatic level transmitters are applicable for the continuous level measurement of clean or chemically faintly contaminated liquids in wells, open reservoirs or tanks. The NC type is recommended for level detection of polluted water. The NIVOPRESS is easy to install into already existing tanks and in deep drilled wells and is especially recommended for controlling submersible pumps. The use of the supplemental accessories is recommended. Using the NAW-104 sewage adapter direct contact between the sewage and the diaphragm of the built-in pressure sensor can be avoided. 2-wire types are available with built-in 4-wire Pt100 temperature sensor or separate 2-wire temperature transmitter. 2-wire types (except **NC□-2□□-□**) have HART communication interface. The **N□K-5□□-□ Ex** types can be used in explosion hazardous environment.

2. TECHNICAL DATA

PROBE

TYPE	2 WIRE		3 WIRE
	NP, NZ	NCK-2/NCP-2	NPH, NZH
Measurement range	0 ... 200 m water head	0 ... 20 m water head	0 ... 200 m water head
Overload allowed (as a function of range)	3x	As per order code 20x (h ≤ 3 m w.h.) 10x (> 3 m w.h.)	3x
Output	4 ... 20 mA + HART	4 ... 20 mA	0...+10 V (0 V ≤ 80 mV)
Power supply	12 ... 30 V DC		18 ... 30 V DC/6mA
Max. load (U _t = power supply; U _{min} = min. power supply) 12 V	$R_{min} = \frac{(U_t - U_{min})}{0.02A}$		≥ 5 kOhm
Temperature transmitter NPD, NZD types	Power supply: 12...30VDC / 4...20mA; 0...+60°C, accuracy ±3°C		
Temperature sensor, Pt100 B	NPP and NZP types	NCP-2 types	-
Linearity error (level transmitter)	±0.25%		
Temperature error (level transmitter)	≤ ± 0.1 % / 10 K		≤ ± 0.2 % / 10 K
Operating temperature*	-10 ... +60°C	0 ... +60°C	-10 ... +60°C
Mechanical connection	NAA-209-es cable mounting wedge clamp, NZ types with 3/4" BSP thread		
Mechanical protection	IP 68		
Electrical protection	Class III.		
Electrical connection	Shielded cable with breathing capillary Ø 7 mm		
Wire cross section	0.34 mm ²		
Cable length	0 ... 300 m as per order code		
Dimensions	NP: Ø 22x179 mm NZ: Ø 38x174 mm	Ø 40x146mm	NPH: Ø 22x179 mm NZH: Ø 38x174 mm
Mass	NP: probe: 0.2 kg NZ: probe: 0.3kg	probe: 0.4 kg	probe: 0.2 kg
	Cable: ~ 0.06 kg/m		
Wetted parts	Sensor	1.4404	Al ₂ O ₃ ceramic
	Housing		1.4571
	Cable coating		Polyurethane / FEP
	Sealing		VITON (FKM)
Protecting cap	ABS	-	ABS

* special order max. +75°C

Manufacturer:
NIVELCO Process Control Co. 
H-1043 Budapest, Dugonics u. 11.
Phone: (36-1) 889-0100 ■ Fax: (36-1) 889-0200
E-mail: sales@nivelco.com ■ www.nivelco.com

2.1 ACCESSORIES

- User's Manual
- Warranty Card
- Declaration of Conformity

ADDITIONAL DATA FOR EX APPROVED MODELS

TYPE	NPK/NPP/NZK/NZP-5□□-□
Power supply	14...30 V DC
Ex marking	 II 1 G EEx ia IIC T6 U _i = 30 V, I _i = 100 mA, P _i = 0.8 W
Intrinsic safety	C _i = 12 nF + h x 0.04 nF; L _i = 1.3mH + h x 0.9 µH (h = cable length)

ACCESSORIES

CABLE TERMINAL BOX	NAA-101	
Dimensions	93 x 93 x 55 mm	
Ingress protection	IP 65	
Operating temperature	-40 °C ... +70 °C	
Material	Polistyrol	
Cable gland	M20x1.5 (cable Ø 5... Ø 10 mm)	
Electrical connection	Terminal block for cable with max. cross section of 2.5 mm ²	
CABLE TERMINAL BOX WITH OVERVOLTAGE PROTECTION *	NAA-102	
Data	See: NAA-101	
Electrical data	See: OVP	
CABLE MOUNTING WEDGE CLAMP	NAA-209	
Max. mech. load	300 m cable	
Operating temperature	-20 °C ... + 60 °C	
OVERVOLTAGE PROTECTION	OVP12/33 *	OVP32/33 *
Mounting	outdoor	DIN 35 mm rail
Dimensions	72 x 42 x 19 mm	62 x 65 x 18 mm
Ingress protection	IP 54	IP 20
Breakdown voltage	33 V	
Absorbed energy	600 W / 1 ms	
Internal resistance	13 ohm	
Leakage current	≤ 10 µA	

* only for 2-wire 4...20mA equipments

2.2 ORDER CODE (NOT ALL COMBINATIONS POSSIBLE!)

NIVOPRESS N - -

TYPE	CODE	OUTPUT	CODE	VERSION	CODE	MEASURING RANGE*	CODE	LENGTH	CODE	LENGTH	CODE		
Capacitive	C	2-wire 4 ... 20 mA +HART	K	Normal NC	2	1 m w.h.	1	0 m	0	Up to 100m	0 m	0	
Piezo / PUR cable	P	3-wire 0 ... 10 V DC	H	Normal	4	2 m w.h.	2	10 m	1		:	1 m	1
Piezo, threaded / PUR	Z	4...20mA, level + HART and	D	Ex	5	5 m w.h.	3	:	:		:	:	:
Piezo / FEP cable	F	4...20mA temperature				10 m w.h.	4	90 m	9		9 m	9	
		4...20mA + HART and Pt100B	P			20 m w.h.	5	100 m	A	Over 100m	0 m	0	
						50 m w.h.	6	200 m	B		10 m	1	
						100 m w.h.	7	300 m	C		:	:	
						200 m w.h.	8				90 m	9	

ACCESSORIES

Cable terminal box	NAA-101	Sewage adapter	NAW-104 (for NP types)
Cable terminal box with OVP	NAA-102		
Cable holding assy	NAA-105	OVP units	OVP12/33 (outdoor)
Cable mounting wedge clamp	NAA-209		OVP32/33 (DIN rail)

* can be set within the range on special request

2.3 DIMENSIONS

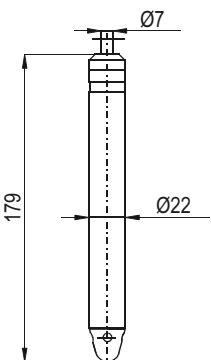
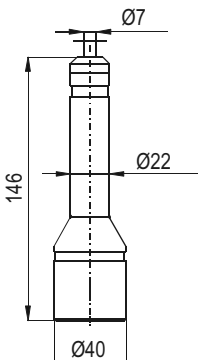
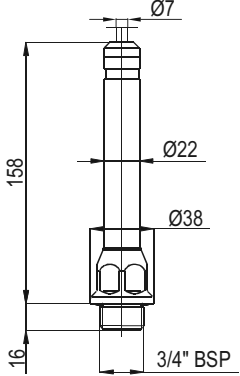
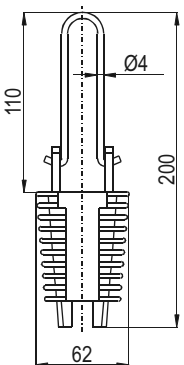
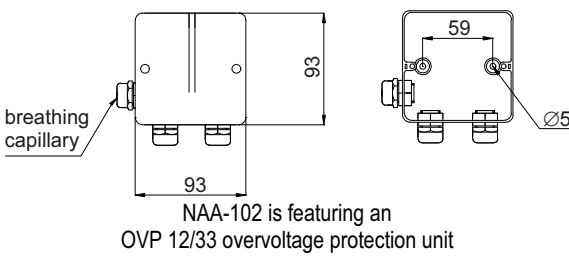
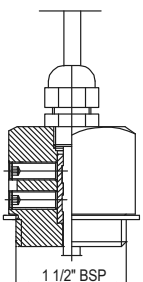
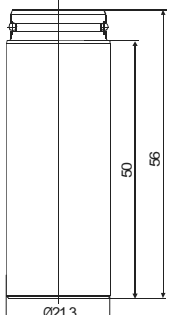
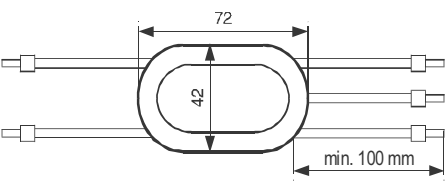
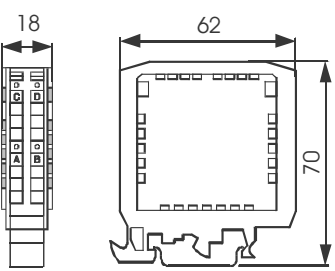
NIVOPRESS NP PROBE	NIVOPRESS NC PROBE	NIVOPRESS NZ PROBE	CABLE HOLDING WEDGE CLAMP NAA-209
			
CABLE TERMINAL BOX NAA-101 and NAA-102	CABLE HOLDING ASSY NAA-105	SEWAGE ADAPTER NAW-104	
			
OVP 12/33 OVERVOLTAGE PROTECTION UNIT		OVP 32/33 OVERVOLTAGE PROTECTION UNIT	
			

3. INSTALLATION

For fastening the cable use NAA-209 cable mounting wedge clamp that provides a solution for hanging the cable without slipping and risk of rupture.

For the NP types the NAW-104 sewage adapter can be snapped in the place of the plastic protecting cap.

For the NZ types the NAZ-103 threaded sewage adapter can be used.

STEPS OF INSTALLATION

– Feed the special cable through the glands, arrange proper length of cable and fasten the cable with the glands.

– Excessive cable parts have to be wound on a pipe with a min. diameter of 100 mm.

The special cable must not be cut short!

– Let the probe down to the lowest possible point, as only the height of the liquid above the probe will be measured.

For connecting the special breathing cable and the signal cable use the cable terminal box **NAA101** or **NAA102** (with IP65), that accommodates the cable end in an ambience free of dust and humidity. Fasten the cable terminal box (e.g. by the use of 2 pcs of M4 screw) to a plain surface. In open air or industrial applications the transmitter should be protected against transient surges / overvoltage.

The GND of the OVP must be connected with the shortest possible wire to the protecting ground. In this case it is suggested the **NAA-102** terminal box (with OVP) is installed close to the location of the measurement. At the opposite end of the cabling the use of an additional over-voltage protection (**OVP12/33** or **OVP32/33**) is advised close to the processing unit. If safety is a priority, use of a protecting electrode enhances the efficiency of the electrical protection.

MOUNTING EXAMPLE

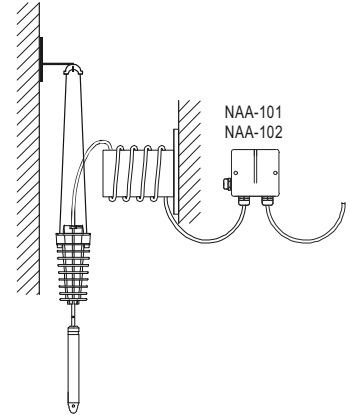

4. WIRING

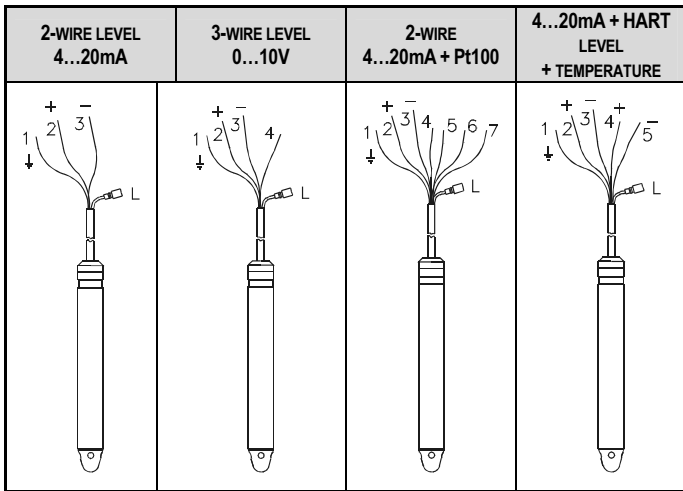

Legend:

	CABLE CORE	COLOUR
1	Shielding	Yellow
2	Positive power supply	Red
3	Negative power supply	Black with an additional blue-coloured insulation
4	Voltage output (3-wire types); NPP/NZP types: Pt100 sensor current drive; NPD/NZD types: positive power supply of the temperature transmitter	Uncoloured
5	NPP/NZP types: Pt100 sensor current drive; NPD/NZD types: negative power supply of the temperature transmitter	Uncoloured + blue shrinkable tube
6	NPP/NZP types: Pt100 sensing	Black
7	NPP/NZP types: Pt100 sensing	Black / red
L	Breathing capillary with vapour filter	-

2-WIRE 4 ... 20 mA

3-WIRE 0 ... 10 V DC

Wiring of OVP 12/33

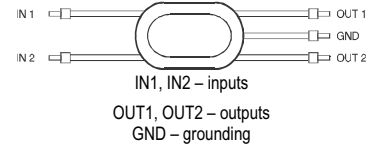
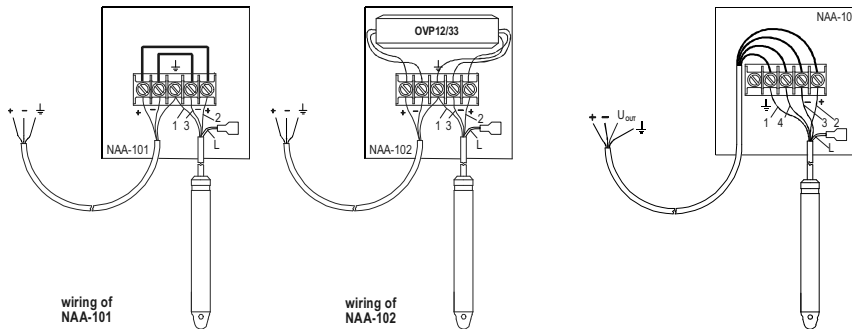

WIRING OF OVP 32/33

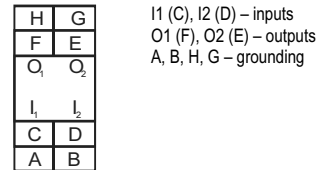

4.1 SAFETY REGULATIONS FOR THE EX APPROVED UNITS

The 'Ex' type hydrostatic level transmitter must be operated in intrinsically safe circuit only (see values in technical data for Ex approved units).

The metal housing of the device must be connected to the EP network using the connection cable marked with 1.

INSTALLATION EXAMPLE USING OVP UNITS

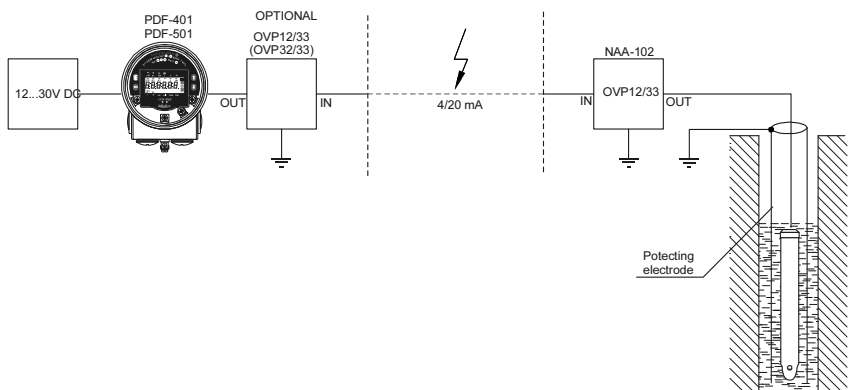

5. PUTTING INTO OPERATION, CONFIGURATION

The unit installed and wired according to the specification is immediately operable, however the specified accuracy will be reached in six-hour time with short cable and in twenty four hour time with a cable of 300 m length. If correction of insertion length is needed loosen the cable holding assy then place the probe to the desired level and finally fasten the cable holding assy.

5.1 REMOTE PROGRAMMING

HART capable transmitters can communicate using standard HART commands with NIVELCO's MultiCONT universal process controller or through a HART-USB adapter (SAT-304 or SAK-305) with a PC. The instrument can be programmed from MultiCONT or from a PC using the attached software EView or NPCAL. With the help of the NPCAL software the measuring range can be downscaled to 50% of the nominal range. The MultiCONT can power the two-wire transmitters and can transmit the measured values via RS485 communication line (for further details see the manual of MultiCONT).

5.2 DESCRIPTION OF PARAMETERS AND PROGRAMMING

P0: --- a Pressure value assigned to 4mA

P1: --- a Pressure value assigned to 20mA

P0 and P1 pressure values can be assigned to the 4mA and 20mA current output values.

When changing the factory set values make sure that the entered values fall within the specified range of the pressure transmitter otherwise the instrument will indicate error.

FACTORY SETTING:

P0 = [minimum measurable pressure value of the sensor] mH₂O (usually 0000)

P1 = [maximum measurable pressure value of the sensor] mH₂O

P9: Current generator test (mA)

With this parameter the user can test the current output by entering a value between 3.9 and 20.5mA and test it with an ammeter.

Warning: the test mode can be cancelled only by entering 0000 to P9.

P10: --- a Measuring mode

a		Measuring mode
0	mbar	Pressure
1	psi	
2	m H ₂ O	
3	ft H ₂ O	Level (water head)

FACTORY SETTING: P10=2

P12: --- a Error indication by the current output

a	Error indication
0	< 3.9 mA
1	> 21 mA

FACTORY SETTING: P12=0

P13: HART short address (Polling address)

If multiple HART capable transmitters are used in a loop the instruments have to be distinguished by their polling addresses. If polling address is 0 (default) the current output is 4...20mA and HART communication works on the 4...20mA current signal. Conforming to the HART standard max. 15 HART devices can be connected to a HART loop with polling addresses between 1 and 15. Thus the output current will be set to 4mA and only the digital HART communication will work. Instruments connected to the same loop should not have same polling addresses or 0 polling address set.

FACTORY DEFAULT: P13=0

P14: Software version

It is a read-only parameter, identifies the software version of the instrument.

P19: Secret code

The settings can be protected by a 4 digit secret code.

If the secret code is active the parameters can be read out but not changed.

To change or clear the secret code the old code should be entered first and then the P19 can be changed to the new code or 0000 (disable secret code).

FACTORY SETTING: P19=0000

Error codes

Code	Error	Procedure
0	Sensor error - the signal of the sensor is out of the calibration range	Contact NIVELCO!
1	Memory error	Contact NIVELCO!
3	Programming error: value of P0 and P1 is not correct	Modify the programming!

6. MAINTENANCE, REPAIR

The unit does not require regular maintenance. In some instances, however, the probe may need occasional cleaning to remove surface deposits within the protective cap that can be easily snapped off (NPK types). Do not touch the sensor membrane. Repairs during or beyond the warranty period are to be carried out solely by the Manufacturer. Equipments sent back for repair should be cleaned or sterilised by the User. The User must declare that the above has been carried out.

7. STORAGE CONDITIONS

Ambient temperature: -10 °C ... +50 °C

Relative humidity: max. 85%

8. WARRANTY

All NIVELCO products are warranted free of defects in materials or workmanship for a period of three years from the date of purchase, as indicated in the Warranty Card.

npk4110a0600h_01

2011. March

NIVELCO reserves the right to change technical data without notice!