



15" Panel PC / Monitor

up to IP67 protection - individually configurable

- Completely sealed housing, made of V2A / V4A stainless steel
- Touch screen: resistive, glass-film-glass (GFG) or PCT-Multitouch
- Protection class: up to IP67 (waterproof, dust-tight)
- Fanless Processor: Intel® ATOM™ N2600 / N2800, Intel® Bay Trail-M N2930 or Intel® Core™ i3
- Extended temperature range -20°C to +70°C
- Sunlight readable display by Optical Bonding



Description

The high-quality industrial Panel PCs and monitors of product line „Taurus“ are absolutely rugged and durable. The polished V2A / V4A stainless steel housing with protection class IP65 or IP67 is completely sealed. Because of the smooth surfaces - especially the True Flat Front - are the products of the "Taurus" line easy to clean and suitable for use in areas with high hygiene requirements.

A compact and rugged construction and the existing level of IP rate protects the PC against dirt, dust, humid environment and other extreme applications.

The hardware is constantly state of the art and provides enough space for future designs and applications. Individual product adaptations/solutions can be realised in accordance with customer requirements.

Applications

- Chemicals & Pharma
- Food & Beverage
- Industrial automation
- Warehouse & Logistics
- Outdoor

Different versions (in each case available as Panel PC or Monitor - individually configurable)



IP65 - Protection
 - cable inlet at the bottom of the case
 - commercially available cables can be used



IP67 - Protection
 - screwable IP67 connectors on the back side



IP67 - Protection
 - True Flat-Front
 - screwable IP67 connectors on the back side





15" Panel PC / Monitor

up to IP67 protection - individually configurable

Specifications

	Monitor	Panel PC			
Display	15" LED - 400 cd/m ² - 1024 x 768				
Viewing Angle	H/V 160°/160°				
System					
CPU	-	N2600 - 1.6 GHz	N2800 - 1.86 GHz	N2930 - 1.83 GHz	Intel® Core™ i3
Chipset	-	Intel® NM10 EXPRESS			Intel® QM77
Memory	-	DDR3 max. 2GB	DDR3 max. 4GB	DDR3L max. 4GB	DDR3 max. 8GB
Storage	-	1x 2,5" SSD / HDD (optional) - 24/7 continuous operation			
Connections I/O	other connections on request!				
IP65	1 x VGA 1 x DVI	2 x LAN 4 x USB 1 x RS 232/422/485			2 x LAN 2 x HDMI 4 x USB 1 x RS 232/422/485
IP67	1x VGA 1x DVI (optional)	1 x LAN 2 x USB 2 x RS232/422/485			1 x LAN 2 x USB 2 x RS232/422/485
Expansion interface	-	1x Mini PCI-E (internal)			
Wireless LAN	-	with an external antenna IP67			
Touchscreen	Resistive / GFG (optional) / PCT-Multitouch (solely in the TrueFlat version)				
Operating voltage	12V DC / 24V DC / 110-240V AC (optional)				
Mounting	VESA 75				
Dimension (WxHxD)	IP65 - 403 x 327 x 78.5 mm IP67 - 403 x 327 x 64 mm				
Weight	~ 8 kg (depending on the version)				
Work environment					
Temperature range	Operating Storage	0° to +50° C -20° to +60° C			
Extended temperature range	(optional)	-20° to +70° C			
Relative air humidity	Operating Storage	10% ~ 95% @ 40° C (non-condensing) 5% ~ 95%			
Vibration	Operating Storage	2 - 9 Hz: Amplitude 3mm / 9 ~ 200Hz: 1G 2 - 8 Hz: Amplitude 7,5mm / 8 ~ 200Hz: 2G / 200 ~ 500Hz: 4G			
Protection class	IP65 / IP67 (optional)				
Certification	CE, ROHS, IP				
Systems software	Windows XP / Windows 7 / Windows 8.1 (Desktop- and Embedded- versions) / LINUX				



15" Panel PC / Monitor

up to IP67 protection - individually configurable

Accessories

<p>Cables with IP67 connector</p>	<p>Power supply 12V DC / 24V DC Power supply 100-240V AC LAN (RJ45) USB COM (RS232) VGA</p>	
<p>Stand support / Mounting bracket</p>	<p>Stand Ceiling mount- / desk support (with fixing holes) Wall bracket Keyboard bracket/ -tray</p>	
<p>Industrial keyboard stainless steel IP65 (vandal-resistant)</p>	<p>Different sizes, different options (Number pad, Touchpad, Trackball)</p>	
<p>Printer</p>	<p>Thermal printer (different printing widths, different options)</p>	
<p>Bar code - scanner</p>	<p>1D / 2D (different versions, IP rating up to IP65)</p>	
<p>Scales</p>	<p>Stainless steel Weight: 3 - 6 - 15 - 30 kg</p>	
<p>Weight display</p>	<p>Scale terminals (different versions, IP rating up to IP67)</p>	





15" Panel PC / Monitor

up to IP67 protection - individually configurable

Dimensional drawing

Version IP65 - 403 x 327 x 78.5 mm (WxHxD)

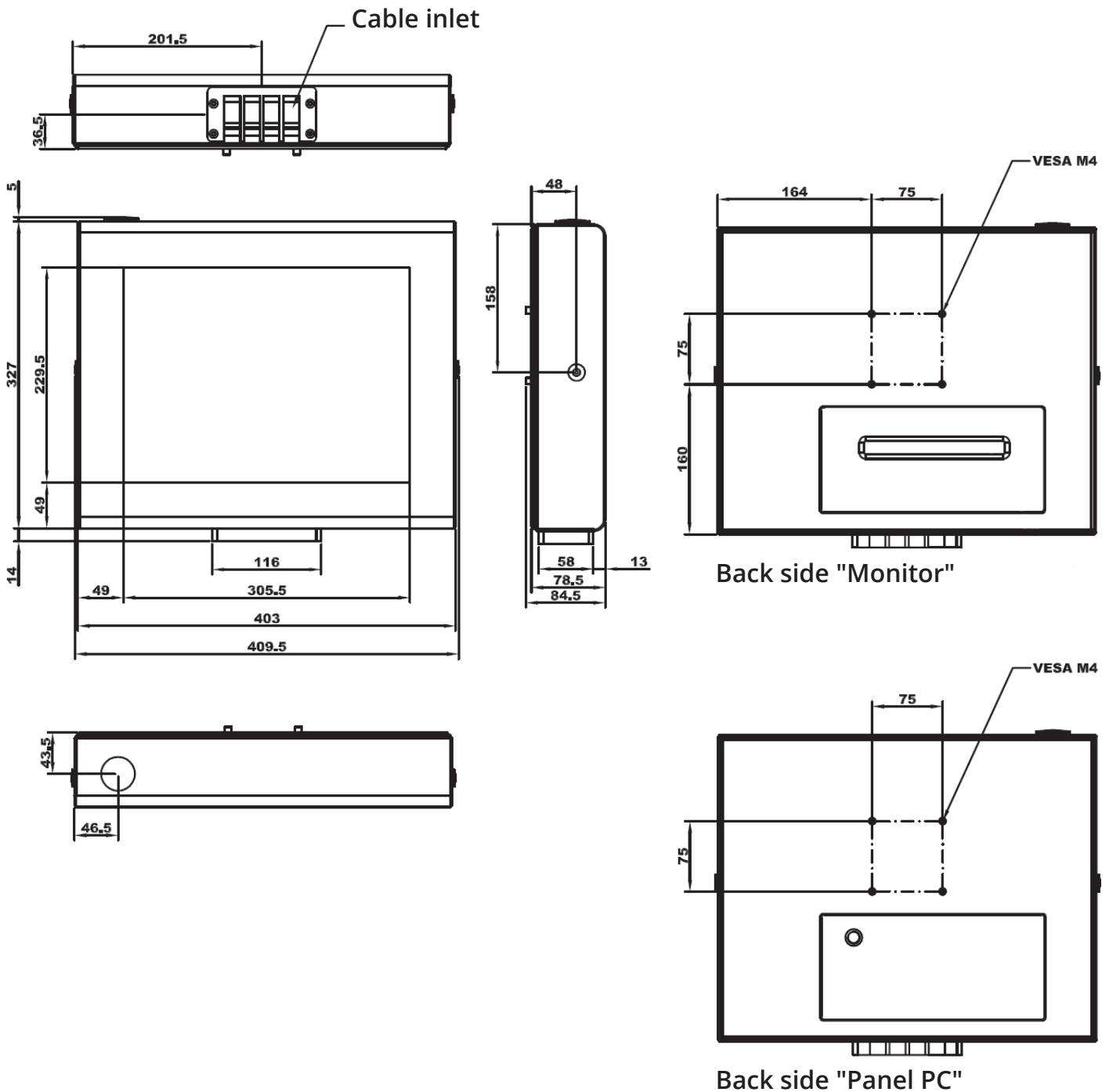



15" Panel PC / Monitor

up to IP67 protection - individually configurable

Dimensional drawing

Version IP67 - 403 x 327 x 64 mm (WxHxD)

